

Model N-64 Belt Scale System



(800) 792-7427 OR (352) 628-6674



Model N-64 Belt Scale System



The Bulk Pro Systems Model N64 Precision Belt Scale System is designed for high speed, high capacity belts which require precision accuracy. It is our most accurate belt scale system to within $\pm 0.25\%$ or better. It can help you monitor production, confirm incoming product, load out outgoing product and monitor product inventory. This belt scale system provides crucial information for the successful management and efficient operation of your plant.

The Bulk Pro Systems Model N-64 Precision Belt Scale System is designed for all high speed, high capacity belts which require precision accuracy. Its heavy duty weigh bridge is widely accepted in harsh industrial environments. The Model N-64 allows you to accurately control feed rates to crushers, bunkers, boilers, stockpiles and other processes with a guaranteed accuracy of $\pm 0.25\%$. It can help you automate your production output, inventory or load-out and provide you with crucial information for the running of your plant.

The Bulk Pro Systems Series N-64 incorporates either a two idler (N-64-2), or four idler (N-64-4) full floating weighbridge assembly, the Model N60 Belt Speed Sensor, the powerful microprocessor based electronics of the Bulk Pro Systems Model 6101 Integrator and the NEMA-4 j-box assembly. These weighbridges can be applied in conveyors with belt widths from 18" (450mm) to 96" (2,440mm).

The N-64 Belt Scale System is easy to install and can be mounted inside or out. It's heavy duty construction allows for installation in industrial and extreme environments. The N-64 weighbridge uses four load cells mounted in tension, ensuring reliable and precise performance. It has no pivots or moving easily worn parts and a robust steel tube construction that allows for minimal material build-up.

The Model N-64 is the most reliable solution for your high accuracy, high speed industrial belt scale applications.

For More Information or a Quotation, Contact Your Bulk Pro Systems Dealer Today:



P. O. Box 2169, Crystal River, FL 34423
Www.GulfAtlanticEquipment.com Info@GulfAtlanticEquipment.com
800-792-7427 352-628-6674 352-628-6774—FAX

Load Cell

- Single Point Strain Gauge
- Housing: Stainless Steel
- Excitation: 10VDC ± 5%
- Load cell output: 3.0 mV/V
- Nonlinearity: <0.03% FS
- Repeatability: <0.01% FS
- Hysteresis: <0.02% FS
- Operation temperature: -22~158°F (-30°C~ +70°C)
- Temperature Sensitivity:
 - Span 0.002% FS/°C
 - Zero 0.002% FS/°C
- Safe Overload: 150% of load cell capacity

6101 Series Integrator

- Enclosure, Field mount:
 - Outline dimensions: 12.28x15x5.91" (312x380x150mm)
 - Mounting hole dimensions: 9.45x17.72" (240x450mm)
- Enclosure, Panel mount:
 - Outline dimensions: 11.34x5.67x7.28" (288x144x185mm)
 - Front Panel dimensions: 11.18x5.51" (284x140mm)
- Temperature Rating:
 - Operating: 14 to 122°F (-10 to 50 °C)
 - Storage: -40 to 158°F (-40 to 70 °C)
- Power Requirements:
 - 120/220 VAC ±10% Switch Selectable
- Display Resolution:
 - LCD 320x240 pixels, English/Chinese language with graphs displayed on-screen: histogram, curve graph, etc.
- Keypad:
 - 25 operating keys. All keys provide tactile feedback
- Measurement Unit:
 - Tons, Kg
- Memory:
 - FRAM memory, data retention when power is interrupted or disconnected.
- Accuracy / Non-Linearity:
 - Less than 0.01% of net for load ranging from 0% to 105% of full scale.
- Circuit Construction:
 - 32-bit RAM Microprocessor, with built-in watchdog preventing system halt, 24-bit A/D converter, real-time clock system.
- 8 programmable open collector outputs
- 6 programmable open collector inputs
- Analog 4-20mA Output & Pulse Output
- Expansion Slots, 3 for optional communications
- Shipping weight:
 - Field Mount, 30 lbs (13.6 Kg)
 - Panel Mount, 8 Kg



Model N60 Speed Sensor

The model N60 speed sensor is used for series N64, N62 and N61 belt scales. Sensor is directly coupled to the conveyor tail pulley or any other non-driven pulley with a minimum of 15-30 degrees of wrap.



The speed sensor is a brushless pulse generator which gives a series pulse. Each pulse represents one unit of belt travel, the pulse frequency is proportional to belt speed.

- Die cast aluminum housing, weather proof.
- Yellow urethane enamel finish.
- Brushless AC pulse generator requires no adjusting or replacement of brush.

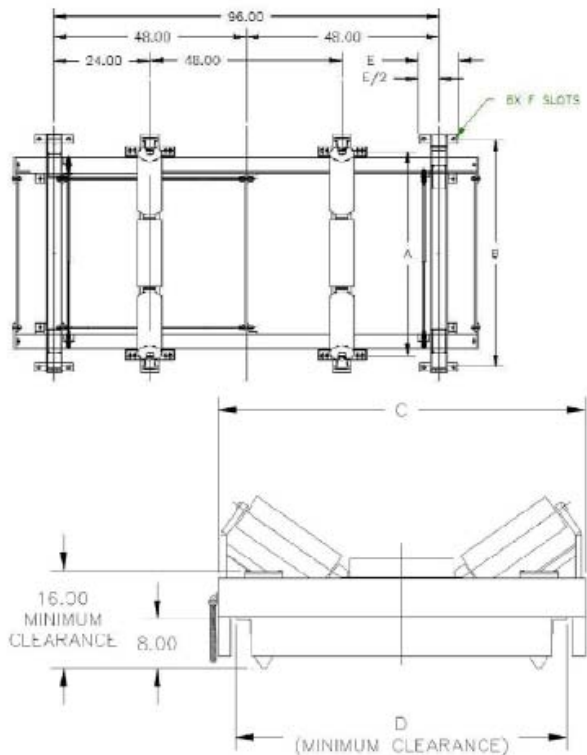

BULK PRO SYSTEMS MODEL N64-2-48 DUAL IDLER BELT SCALE						
DIMENSIONS (INCHES)						
BELT WIDTH	A	B	C	D	E	F
18	21.25	27	29.50	23.25	7.5	9/16 x 1
24	27.25	33	35.50	29.25		
30	33.25	39	41.50	35.25		
36	39.25	45	47.50	41.25		
42	45.25	51	53.50	47.25	10.00	13/16 x 1
48	51.25	57	59.50	53.25		
54	57.25	63	65.50	59.25		
60	63.25	69	71.50	65.25		
72	75.25	81	83.50	77.25		

A minimum of 10" must be allowed between the return belt & top of stringer

For More Information or a Quotation, Contact Your Bulk Pro Systems Dealer Today:



P. O. Box 2169, Crystal River, FL 34423
 Www.GulfAtlanticEquipment.com Info@GulfAtlanticEquipment.com
 800-792-7427 352-628-6674 352-628-6774—FAX