

UNIVERSAL ENGINEERING

JAW CRUSHERS

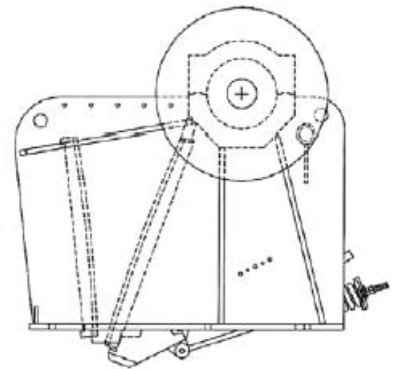

- VERSATILITY - DURABILITY - PROFITABILITY -

CONTACT YOUR
UNIVERSAL DEALER

**Gulf
Atlantic**

INDUSTRIAL EQUIPMENT INCORPORATED
Concrete, Aggregate, and Material Handling Equipment
Concrete Solutions with Rock Solid Results
800-792-7427

Info@
GulfAtlanticEquipment.com

GREATER CAPACITY, FLEXIBILITY AND PRODUCTION

(800) 792-7427



With its original overhead eccentric principal, Universal Engineering Corp. brought double crushing action to the rock producers of America over several decades ago and made crushing a profitable business.

Universal Engineering's overhead eccentric Jaw Crusher continuously reduces the rock as it passes through the crushing chamber. The resulting force feed action as the jaw moves in its inward, downward path, turns out more tons per hour at lower costs per ton. The sharp primary blow at the top of the jaws reduces material instantly, most of it to spec size. Then the additional secondary crushing action at the bottom of the jaw further reduces any remaining oversized material. All this time the force feeding action is moving material through the crusher at phenomenal rates, clearing the jaws for more feed material. The result is more spec material at a lower cost and more profit in your operation.

Universal's overhead eccentric jaw crushers last longer and crush longer because they are constructed from top quality materials to a field-proven design. These crushers are built with brute strength for rugged service in a tough industry.

There are many attempted copies of the Universal overhead eccentric Jaw Crushers, but few have challenged Universal's superiority. Daily reports from Universal Jaw Crusher owners throughout the world, some of them in service for 70 years and still going strong, lend proof to Universal's superiority and durability in the industry. There is a size to meet your needs and requirements!



Universal Engineering offers H-Series Jaw Crusher with "Adjust-on-the-Fly" technology, while maintaining a reputation for an aggressive "Nip Angle" and "Consistent Crushing" throughout the entire chamber. With Adjust-on-the-Fly capabilities, the H-Series provides Single-Action Controlled:

- Hydraulic Discharge Setting Adjustment
- Chamber Clearing
- Auto-Reset after tramp iron relief

Unlike most major competitors, the H-Series Jaw Crushers are designed with a bank of small hydraulic cylinders. These cylinders deliver the following:

- Off-the-Shelf components
- Combined force unsurpassed in the industry
- Longer stroke length
- Steeper toggle angle

Beyond the hydraulic actuation, the H-Series Jaw Crushers offer a variety of features that surpass the Traditional Jaw Crusher design, providing additional means to reduce cost and boost profits.

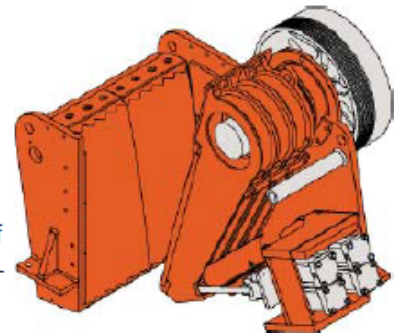

The information contained herein is general in nature and is not intended for specific construction, installation or application purposes. Predictions of actual performance of a given piece of equipment should take into account the many variable field factors, no warranty of any kind, expressed or implied, is extended by presenting the generalized data herein. We reserve the right to make changes in specifications shown herein or add improvements at any time without notice or obligation. Where drive mechanism guards are not shown, they have been removed for illustration purposes only; in actual working conditions these protective devices should never be removed.

**CONTACT YOUR
UNIVERSAL DEALER**

**Gulf
Atlantic**

INDUSTRIAL EQUIPMENT INCORPORATED
Concrete, Aggregate, and Material Handling Equipment
Concrete Solutions with Rock Solid Results
800-792-7427

**Info@
GulfAtlanticEquipment.com**

UNIVERSAL TRADITIONAL JAW CRUSHERS

(800) 792-7427

Perfectly Balanced Flywheels

- Balancing the flywheels gives the machine a smoother action, transmitting less vibration to the structure. The large diameter of the flywheels provide continuous driving force (inertia).

Anti-friction Bearings - Big bearings in the base and pitman provide smooth, power-saving action. These large bearings will take big loads and still have plenty of reserve strength for the unexpected overloads.

Massive Cast Steel Pitman - Heavy reinforcing at every stress point, plus massive hubs, clearly illustrate built-in strength. Carefully controlled annealing after casting assures extra shock resisting power found in few crushers size for size. Close tolerances are maintained in final machining to provide accurate fit of bearings and jaw plates to maintain the balance required by Universal inspection.

Wear-Resistant Heel Plates & Key Wedges

- Protect the base of the jaw crusher preventing any wear to occur on the

Rugged Deep Section Steel Base

- This rigid one-piece fabricated base is stress relieved, jig bored and machined to close tolerances to give the producer a machine with perfect shaft alignment, jaw fit and rugged strength for every job.

Reversible Manganese Jaw Plates

- The reversible and heat-treated wear resistant manganese jaw plates actually get tougher as they work. The extra jaw plate length plus the crushing angle assures instant nip of incoming material. Production-wasting material rebound is held to a minimum. A variety of jaws are available for select models.

Safety Toggle Plate - The dual purpose toggle plate is designed to break when uncrushable material enters the crusher chamber. The toggle plate is also responsible for controlling the stroke at the bottom of the crushing chamber. Set at a steep angle, the toggle provides a sharp secondary blow at the bottom of the jaws and increases forced feed and discharge action.

Rugged Eccentric Shaft

- These rugged eccentric shafts are hammer forged from the finest quenched, tempered and stress-relieved alloys. There is just enough eccentric throw to give clean impact-like crushing and yet avoid harsh rubbing motion which robs horsepower and creates excessive jaw wear.

Hydraulic Shim Jaw Adjustment

- The lower jaw adjustment easily changes the lower jaw openings for fast change of product size. The adjustment can be made quickly and easily with the hydraulic ram to change shims.

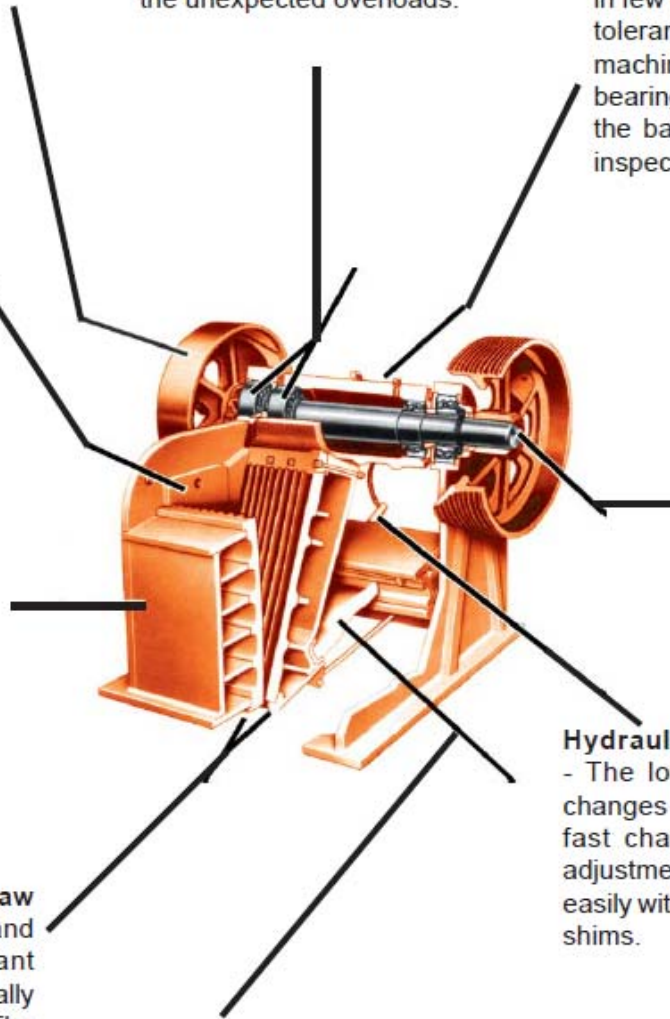

The information contained herein is general in nature and is not intended for specific construction, installation or application purposes. Predictions of actual performance of a given piece of equipment should take into account the many variable field factors, no warranty of any kind, expressed or implied, is extended by presenting the generalized data herein. We reserve the right to make changes in specifications shown herein or add improvements at any time without notice or obligation. Where drive mechanism guards are not shown, they have been removed for illustration purposes only; in actual working conditions these protective devices should never be removed.

**CONTACT YOUR
UNIVERSAL DEALER**

**Gulf
Atlantic**

INDUSTRIAL EQUIPMENT INCORPORATED
Concrete, Aggregate, and Material Handling Equipment
Concrete Solutions with Rock Solid Results
800-792-7427

**Info@
GulfAtlanticEquipment.com**