

UNIVERSAL HAMMERMASTER CRUSHER

(800) 792-7427
(352) 628-6674



The Universal HammerMaster is a crusher that combines the advantages of impact breaking with milling in a single high capacity unit. The massive rotor assembly consists of heavy steel shaft with discs machined from steel plate and drilled to accommodate either two or three rows of hammers. Additional step-out holes permit compensation of wear on hammers and grates. Choice of hammer types includes cast steel fine grinding, yoke-type for coarse crushing and replaceable tip type with manganese tips. The large 36" hammer circle helps generate the high inertia force necessary when producing a high quality cubical product, free of flats and slivers and without excessive fines. This larger hammer circle also permits slower rotor speeds and allows sized material to pass through the grates without excessive grinding. Wide selection of grate sizes and combinations permits close product control as material conditions and/or specifications change. The Universal HammerMaster combines high capacity and low operating cost when processing a non-abrasive limestone into highly cubical construction grade aggregate.

Standard Design Features:

- Welded steel base.
- Hinged cover with manganese impact breaker blocks.
- Sectionalized abrasion resistant steel liners.
- Reversible manganese breaker plate.
- Lower clean out doors on both sides of crusher.
- Tapered grate circle with (3) 1/2", (9) 1", and (5) 2" grates furnished, unless otherwise specified.
- Rotor assembly includes alloy steel shaft with spherical roller bearings down running design.
- One (1) flywheel. One (1) drive sheave.
- 2-1/2" thick rotor discs with step-out holes for two or three rows of nominal 60# reversible manganese bullhead hammers.

Optional Equipment Available:

- Motor sheave
- Drive guard
- V-belts
- Electric motor
- Alternate grate combinations available -

**CONTACT YOUR
UNIVERSAL DEALER**

Gulf Atlantic

INDUSTRIAL EQUIPMENT INCORPORATED
Concrete, Aggregate, and Material Handling Equipment
Concrete Solutions with Rock Solid Results
800-792-7427

**Info@
GulfAtlanticEquipment.com**

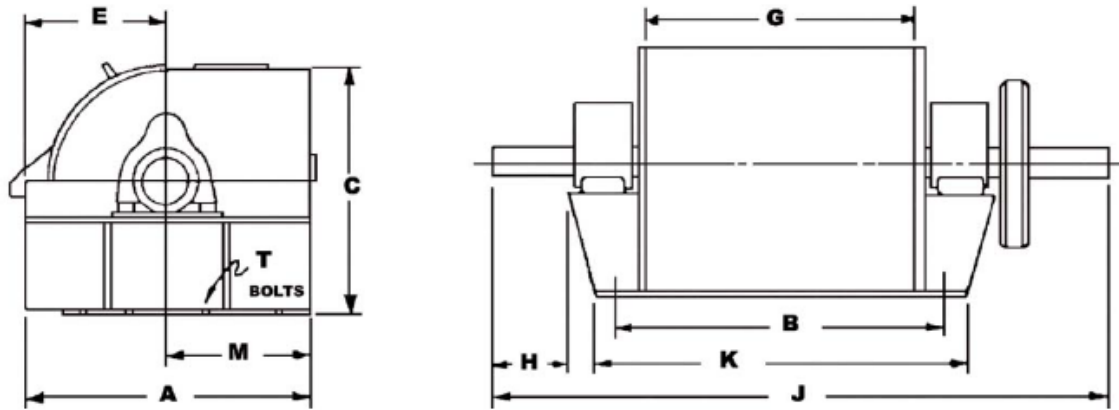

DIMENSIONS

(800) 792-7427 or (352) 628-6674

HAMMERMASTER MODEL		A	B	C	E	G	H	J	K	M	T
2636	in	53.63	33.00	44.75	26.75	26.00	18.81	88.50	39.00	26.88	1.00
	mm	1,362.2	838.20	1,136.6	679.4	660.4	477.8	2,247.9	990.6	682.7	25.4
4136	in	53.63	48.38	44.75	26.75	41.38	14.88	96.00	54.38	26.88	1.00
	mm	1,362.2	1,228.8	1,136.6	679.4	1,051.0	377.9	2,438.4	1,381.2	682.7	25.4
5136	in	53.63	58.63	44.75	26.75	51.63	13.69	103.88	64.63	26.88	1.00
	mm	1,362.2	1,489.2	1,136.6	679.4	1,311.4	347.7	2,638.5	1,641.6	682.7	25.4

SPECIFICATIONS

HAMMERMASTER MODEL		2636	4136	5136
Feed Opening	in	16 x 26	16 x 41	16 x 51
	mm	406 x 660	406 x 1,041	406 x 1,295
Capacity-3/16" (4.8mm) Lime Dust	STPH	40 - 60	55 - 90	70 - 110
	MTPH	36 - 54	50 - 82	63 - 100
Capacity-1" (25.4mm) Road Rock	STPH	90 - 150	120 - 185	150 - 230
	MTPH	82 - 136	109 - 168	136 - 209
Capacity-1-1/2" (38.1 mm) Road Rock	STPH	110 - 180	170 - 220	210 - 275
	MTPH	100 - 163	154 - 200	190 - 249
Weight	lb	9,500	13,000	17,000
	kg	4,310	5,897	7,710
Speed: Ag Lime Road Rock	RPM	1,100	1,100	1,100
	RPM	900	900	900
Horsepower Electric	HP	150	200	250

Capacities based on processing a dry, free-flowing limestone with a maximum feed size up to 6" (152mm). Capacity will vary according to type of material, size, method of feeding, applied horsepower and the grate combination used.

The information contained herein is general in nature and is not intended for specific construction, installation or application purposes. Predictions of actual performance of a given piece of equipment should take into account the many variable field factors, no warranty of any kind, expressed or implied, is extended by presenting the generalized data herein. We reserve the right to make changes in specifications shown herein or add improvements at any time without notice or obligation.

**CONTACT YOUR
UNIVERSAL DEALER**

**Gulf
Atlantic**

INDUSTRIAL EQUIPMENT INCORPORATED
Concrete, Aggregate, and Material Handling Equipment
Concrete Solutions with Rock Solid Results
800-792-7427

**Info@
GulfAtlanticEquipment.com**