

UNIVERSAL (H SERIES) JAW CRUSHERS

*"ADJUST ON THE FLY"
TECHNOLOGY*

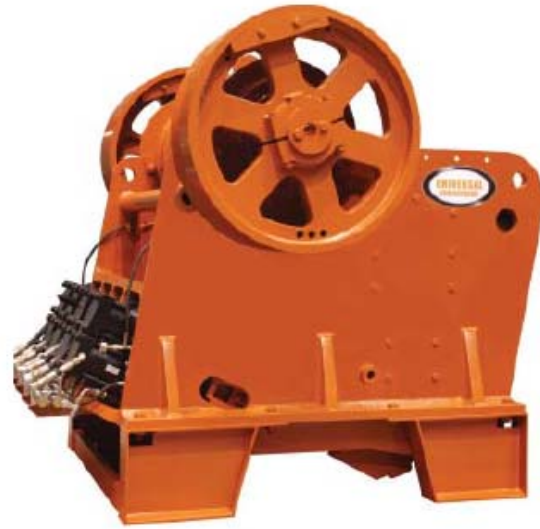

Standard Design Features:

- Rigid one-piece fabricated base frame reinforced for unmatched durability and strength.
- Jaw openings are measured from inside the wear plates providing a true measurement of the crushing chamber.
- Universal Jaw Crushers are known for their deep crushing chambers that reduce rebounding and increase overall throughput. The large eccentric shaft offset combined with a steep toggle angle yields more compressive force throughout the crushing chamber.
- Replaceable three-piece cheek plates prevent wear on the sides of the crusher base and minimize replacement cost (3264 Only).
- Identical and reversible manganese jaw plates provide for a severe duty wear surface that work-hardens and allows for maximum wear life. Replaceable toes on both the stationary and movable jaw (3264 Only).
- Massive steel pitman is heavily reinforced to provide the ability to absorb the shock loads.
- Large balanced flywheels supply continuous driving force to the crushing action.
- Adjust-on-the-fly hydraulic system features a bank of industry-standard cylinders and provides for hydraulic tramp iron relief with auto-reset, hydraulic clearing, and adjustments of the discharge setting at the touch of a finger while under full load.
- Greater throughput combined with low-cost maintenance equals higher profits every day of operation. The Universal Jaw Crusher is field-proven worldwide as an efficient, cost-effective recycle crusher in the toughest environments.

.....

Optional Equipment Available:

- Manual Lube System Piped to Central Location
 - Fully Automatic Lube System Piped to a Central Location
 - V-belts
 - Drive Guard
 - Base Mounted Motor Mount
 - Electric Motor
 - Motor Sheave
-

CONTACT YOUR UNIVERSAL ENGINEERING DEALER TODAY:

INDUSTRIAL EQUIPMENT INCORPORATED
Concrete, Aggregate, and Material Handling Equipment
Concrete Solutions with Rock Solid Results
800-792-7427

(800) 792-7427
(352) 628-6674

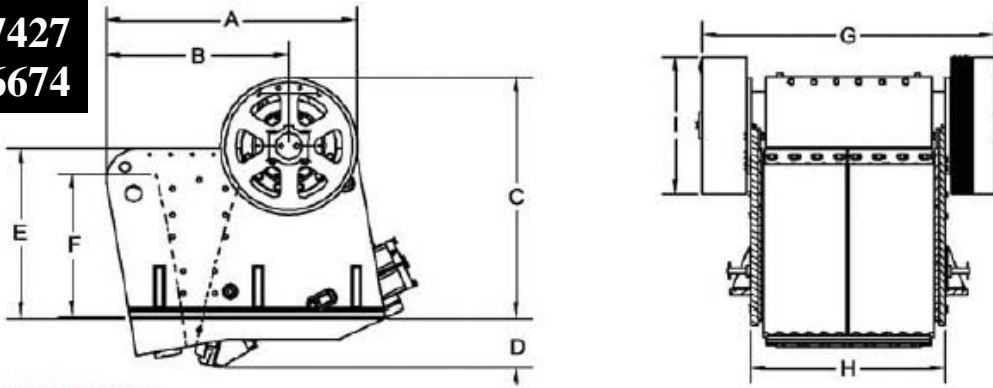

DIMENSIONS

JAW		A	B	C	D	E	F	G	H	I
3242H	in	99.44	68.44	97.25	11.25	70.25	58.50	100.38	66.00	52.00
	mm	2,526	1,738	2,470	286	1,784	1,486	2,550	1,676	1,321
3254H	in	99.44	68.44	97.25	16.00	71.25	58.50	114.00	72.50	52.00
	mm	2,526	1,738	2,470	406	1,810	1,486	2,896	1,842	1,321
3264H	in	105.00	68.82	90.00	19.19	63.00	54.00	110.25	88.75	52.00
	mm	2,667	1,748	2,286	487	1,600	1,372	2,800	2,254	1,321
4250H	in	125.81	81.56	136.00	4.88	101.25	95.25	120.00	74.00	65.00
	mm	3,196	2,072	3,454	124	2,572	2,419	3,048	1,880	1,651

SPECIFICATIONS

Model Number		3242H	3254H	3264H	4250H
Jaw Opening	in	32 x 42	32 x 54	32 x 64	42 x 50
	mm	813 x 1,067	813 x 1,372	813 x 1,626	1,067 x 1,270
Weight	lb	54,000	62,000	70,000	100,000
	kg	24,545	28,120	31,750	45,360
Horsepower	HP	150	200	200	200
Recommended Electric	kW	115	150	150	150
Operating Speed	RPM	225	225	225	225
Eccentric Shaft Material		Forged Steel	Forged Steel	Forged Steel	Forged Steel
Shaft Dia @ Center	in (mm)	13.38 (340)	13.38 (340)	14.00 (356)	14.13 (359)
Shaft Dia @ Pitman	in (mm)	11.81 (300)	11.81 (300)	11.81 (300)	12.60 (320)
Shaft Dia @ Side	in (mm)	10.24 (260)	10.24 (260)	10.24 (260)	11.02 (280)
Shaft Dia @ Flywheel	in (mm)	9.00 (229)	10.00 (254)	10.00 (254)	10.00 (254)
Overall Shaft Length	in (mm)	102 (2,591)	114 (2,896)	110.25 (2,800)	112 (2,845)
Jaw Material		Manganese	Manganese	Manganese	Manganese
Stationary Length	in (mm)	60.50 (1,537)	60.50 (1,537)	65.50 (1,664)	94.00 (2,388)
Movable Length	in (mm)	68.25 (1,734)	68.25 (1,734)	65.50 (1,664)	94.00 (2,388)
Max. Discharge Setting*	in (mm)	12.00 (305)	12.00 (305)	12.00 (305)	16.50 (419)
Min. Discharge Setting*	in (mm)	4.00 (102)	2.00 (51)	3.00 (76)	2.00 (51)
Flywheel Material		Cast Iron	Cast Iron	Cast Iron	Cast Iron
Dia. And Face	in x in mm x mm	52 x 16.75 1,321 x 425	52 x 16.75 1,321 x 425	52 x 16.75 1,320 x 425	65 x 21.00 1,651 x 533

*Measured peak to valley on jaw dies.

The information contained herein is general in nature and is not intended for specific construction, installation or application purposes. Predictions of actual performance of a given piece of equipment should take into account the many variable field factors, no warranty of any kind, expressed or implied, is extended by presenting the generalized data herein. We reserve the right to make changes in specifications shown herein or add improvements at any time without notice or obligation.

**CONTACT YOUR
UNIVERSAL DEALER**



INDUSTRIAL EQUIPMENT INCORPORATED
 Concrete, Aggregate, and Material Handling Equipment
 Concrete Solutions with Rock Solid Results
800-792-7427

**Info@
GulfAtlanticEquipment.com**