

RAILSIDE CAR SHAKER



NAVCO®
NATIONAL AIR  VIBRATOR CO.
Houston, TX

R A I L S I D E

Why Use the Railside Car Shaker?

Call for references

(800) 792-7427

The **NAVCO**[®] Railside Car Shaker is a permanently mounted vibration system designed to speed the loading and unloading of bulk material from railcars.

The high amplitude, low frequency vibrational energy delivered by the Railside Car Shaker's pneumatic drive mechanism is far more effective than the high frequency rotational vibration used in other common railcar flow aid devices. In fact, field tests and live installations of the Railside Car Shaker have proven it's ability to reduce unloading time for especially stubborn material by up to 75%.

How It Works

The Railside Car Shaker is designed to deliver high amplitude, low frequency, linear vibration into the railcar. Vibration transmitted in a plane perpendicular to the flow of the bulk material is transferred into the material more effectively than other methods. This results in the most efficient and effective material movement possible. The operating principals of the design allow for efficient influence of material in the rail cars with low stress to the rail car structure.

Construction & Operation

The standard **NAVCO**[®] Railside Car Shaker is comprised of a unidirectional piston type drive assembly, a pneumatic positioning cylinder and a heavy duty steel chassis.

Operation of the **NAVCO**[®] Railside Car Shaker is easily managed by one person. The controls can be stationed nearby or at a remote location. When the Railside Car Shaker is started the positioning cylinder is activated to extend the chassis so that the contact beam rests firmly against the rail car. Next the drive assembly is energized and loading or unloading begins. Once loading or unloading is completed the drive is de-energized and the positioning cylinder de-activates causing the chassis to return to its retracted position.

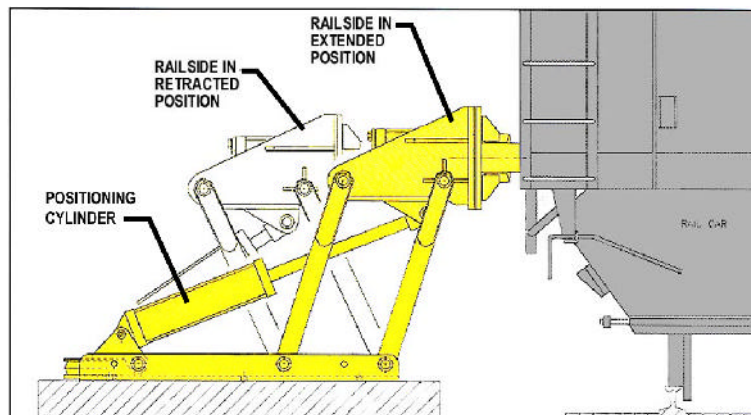

A R S H A K E R

The NAVCO® Railside Car Shaker is available in both pneumatic and electric models. The Roller Railside is manufactured with heavy duty steel rollers at the contact point for continuous unloading of captive cars.

Models



At Left:
1. Standard Installation
2. Electric Railside Shaker
3. Roller Railside Shaker

SAFETY - A permanent installation eliminates the need for employees to carry portable units from car to car and reduces hazards by eliminating the need to manually clean rail cars.

SAVINGS - Labor savings are realized because the entire operation of the Railside Shaker can be performed by one person. Additionally, material cost is reduced because the Railside Shaker completely empties rail cars, eliminating carryback.

SPEED - Increased amplitude at low frequencies creates maximum material movement for faster loading and unloading - proven up to 75% faster!

COST - The compact design and unique dampening features of the Railside Shaker will dramatically reduce installation costs due to minimal anchoring requirements.

Benefits

Hopper Car Portable Vibrators - HCP pneumatic piston vibrators are ideal for jobs that don't require the full heavy-duty action of the Railside Car Shaker. The HCP comes in 3 sizes and the universal mounting head fits all dovetail brackets found on hopper cars. The unique 'freeride' design of the NAVCO®



HCP mounting head prevents the vibrator from getting stuck in the dovetail bracket, a common problem with similar competitor models.

Left: HCP - Hopper Car Portable Vibrator

Overhead Car Shaker - A very heavy duty proprietary design especially for difficult unloading applications. A hoist / trolley system is required to handle the Overhead Car Shaker.



Above: Overhead Car Shaker

Additional Products

RAILSIDE CAR SHAKER DATA

Standard Equipment

- Series 850 unidirectional pneumatic drive assembly
- Pneumatic positioning cylinder
- Recoil damper assembly
- Steel chassis
- Control package including:
 - solid-state timer
 - controls for pneumatic positioning cylinder

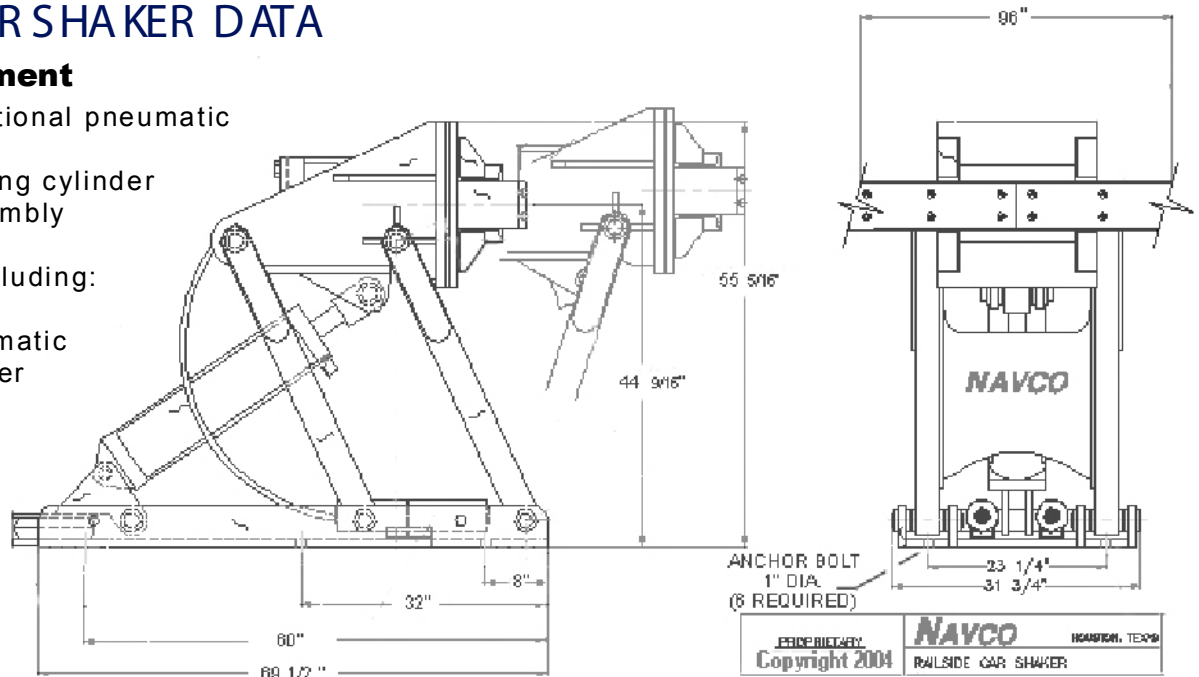

Utility Requirements

- Air pressure: 100 psig
- Air Volume: 180 scfm at 100 psig
- Electrical: 120 VAC (for timer only)

Weight

3200 lbs.

Optional Equipment

- Hazardous area construction
- Electric Drives
- Customized Controls

- Power
- Steel
- Plastics
- Chemicals
- Pulp & Paper
- Food Processing
- Concrete & Aggregates
- Pharmaceuticals
- Feed & Grains
- Automotive
- Ceramics
- Foundry
- Textiles
- Mining



Represented By:



INDUSTRIAL EQUIPMENT INCORPORATED
 Concrete, Aggregate, and Material Handling Equipment
Concrete Solutions with Rock Solid Results
800-792-7427