

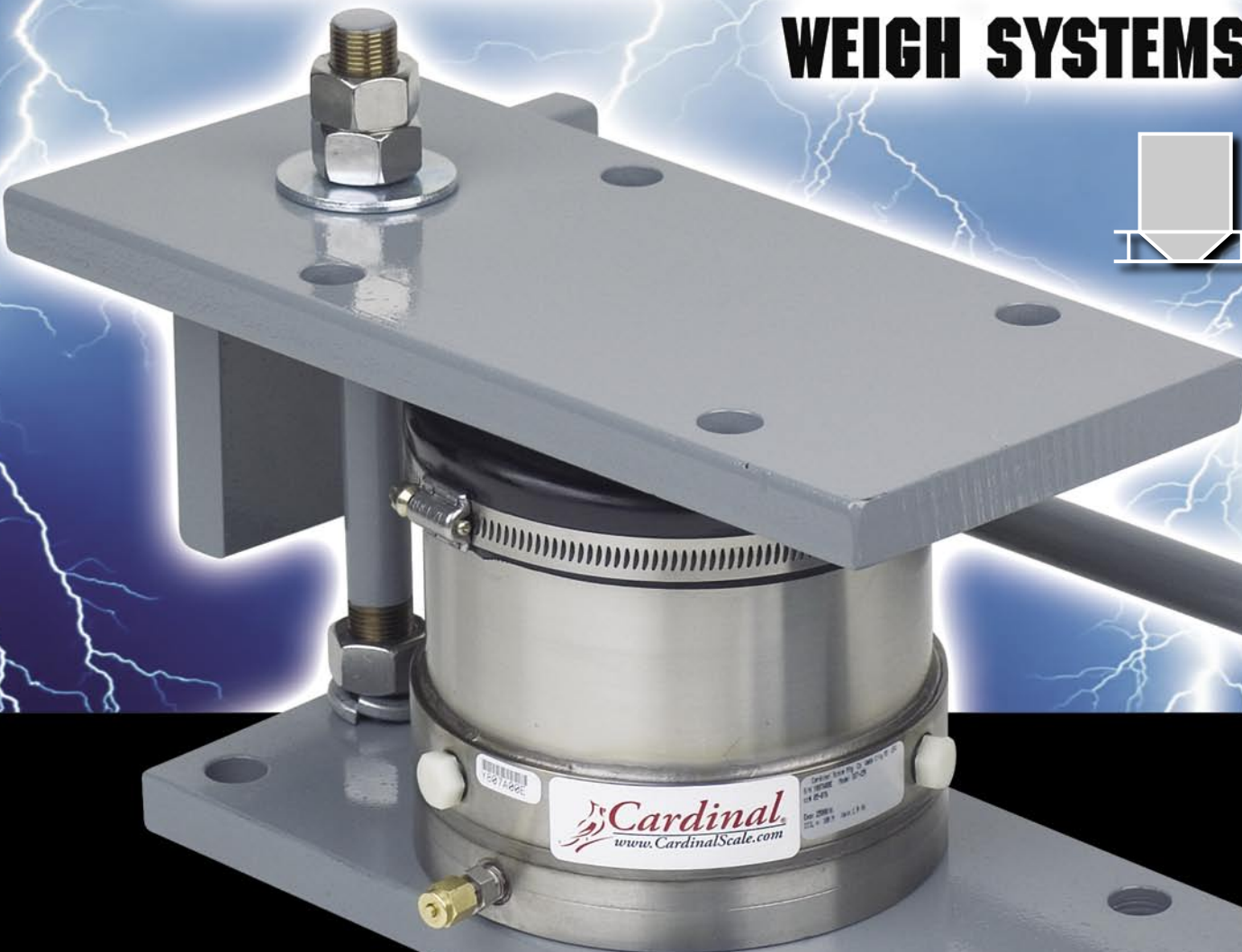

THE
GUARDIAN

**TANK & HOPPER
HYDRAULIC
WEIGH SYSTEMS**



Cardinal's Guardian Tank and Hopper Mounted Scale Systems are designed to keep you weighing even in the harshest conditions. Cardinal's SST hydraulic load cells are built to last a lifetime and are constructed in 300 series **STAINLESS STEEL**. All of this extreme-duty protection means one thing, big savings over the life of your weighing vessels.

PROTECT
Your Weighing Investment



THE GUARDIAN

**The Most Reliable Tank and Hopper Scale
on the Market!**

DESIGNED FOR EXTREME-DUTY, LONG-TERM, RELIABLE WEIGHING

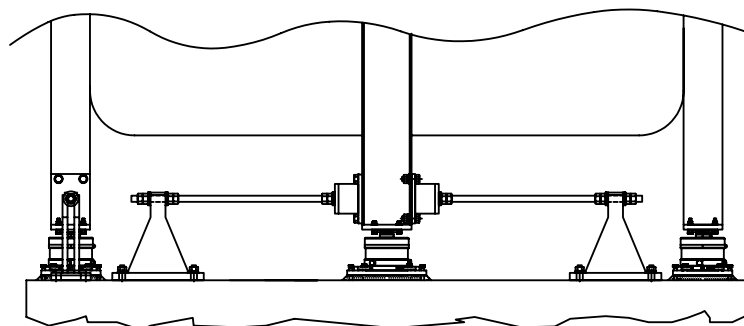
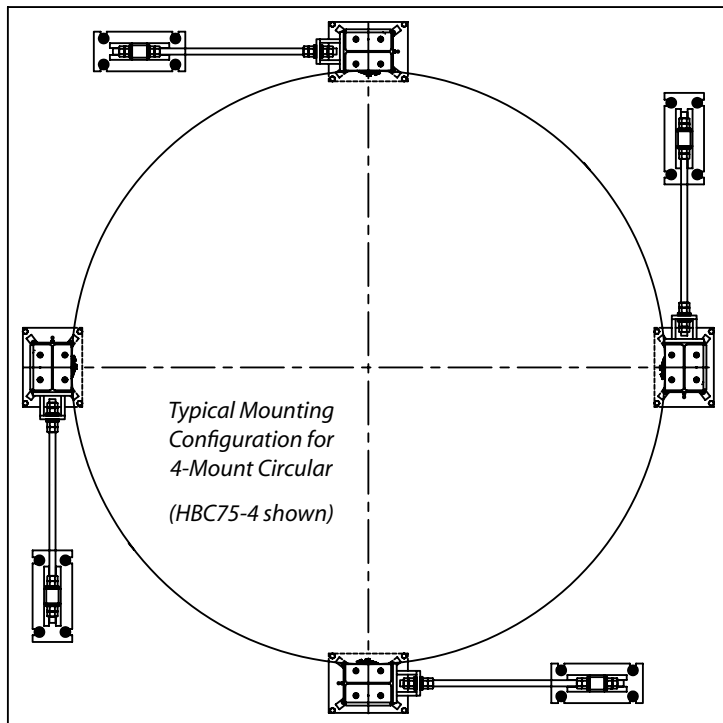

GUARDIAN FEATURES:

- **7,500 - 300,000 lb System Gross Capacities.**
- **Environmentally Sealed (IP68) Cardinal Model SST Load Cells.**
- **Rugged All-Welded Construction.**
- **High-Corrosion Resistance, Stainless Steel Load Cell Construction.**
- **Low-Profile for Easy Installation.**
- **Ideal for New Installations or Existing Installation Conversion.**
- **Available in Your Choice of 3 or 4 Stand Assemblies (4 Shown Left).**
- **Long Life - No Down Time for Repairs and Maintenance.**

Cardinal's Guardian hydraulic floor-mounted load cell kits are ideal for extreme-duty environment tank and hopper scales. They provide a superior level of performance in indoor and outdoor process control operations. Each kit comes complete with load cells, tank mounting hardware, copper hydraulic load cell tubing, and a system totalizer box. The HBC2.5, HBC5, HBC10 and HBC25 models incorporate self-checking capabilities for thermal expansion and contraction. The HBC50 and HBC75 models feature checkrods for additional stability in larger tank and hoppers.



Each system is supplied with a totalizer cabinet and 20 ft of copper or optional stainless steel tubing per load cell.

Cardinal Model HBC25-4 pictured

Self-checking 3 and 4 stand assemblies available.



CARDINAL SST HYDRAULIC LOAD CELL

This heavy-duty all-stainless steel hydraulic compression load cell is the ideal solution for those applications requiring superb accuracy in a hostile environment. Designed for use in vehicle and tank/hopper scales, the SST series hydraulic load cells provide unsurpassed performance.



Immune to **LIGHTNING DAMAGE.**



WATER and HEAVY WASHDOWN reliability.



TRANSIENT VOLTAGE and R.F.I. resistant.



Protected against **RODENT DAMAGE.**



Your lowest possible **MAINTENANCE COST.**

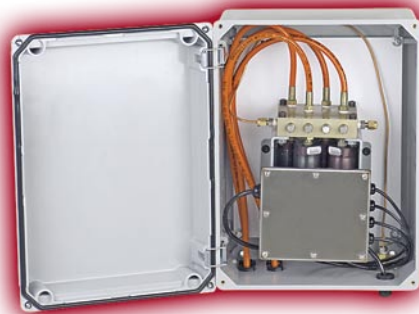

SYSTEM TOTALIZER

The Guardian system totalizer encloses the Cardinal PTG pressure transducers, which are fluidly coupled to the SST hydraulic load cells to convert the pressure signal into an electrical signal for digital weight readouts.

DIGITAL WEIGHT MONITORING

Whether you require weighments on only one hopper/vessel or multiple tanks, Cardinal can provide the right weight controller for the job. Cardinal's model 825 Spectrum and 225 Navigator weight displays can monitor multiple scales and even supply data to your server for additional management tasks. Cardinal has the solution to your weighing application.



Cardinal Model 225 Navigator

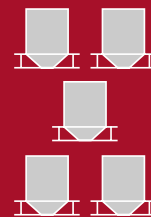

Cardinal Model 825 Spectrum

TANK/HOPPER KITS - THREE LEG ASSEMBLIES

Model Number	System Gross Capacity	No. of Load Cells	Cell Capacity	Individual Stand Dimensions
HBC2.5-3	7,500 lbs	3	2,500 lbs	11.5" W x 4.75" D x 4.6" H
HBC5-3	15,000 lbs	3	5,000 lbs	23" W x 8.31" D x 6.38" H
HBC10-3	30,000 lbs	3	10,000 lbs	23" W x 8.31" D x 7" H
HBC25-3	75,000 lbs	3	25,000 lbs	23" W x 8.5" D x 8.89" H
HBC50-3	150,000 lbs	3	50,000 lbs	14" W x 12" D x 9.3" H
HBC75-3	225,000 lbs	3	75,000 lbs	16" W x 12" D x 9.3" H
HBC100-3	300,000 lbs	3	100,000 lbs	consult factory

Accuracy classification: 0.2% full scale

TANK/HOPPER KITS - FOUR LEG ASSEMBLIES

Model Number	System Gross Capacity	No. of Load Cells	Cell Capacity	Individual Stand Dimensions
HBC2.5-4	10,000 lbs	4	2,500 lbs	11.5" W x 4.75" D x 4.6" H
HBC5-4	20,000 lbs	4	5,000 lbs	23" W x 8.31" D x 6.38" H
HBC10-4	40,000 lbs	4	10,000 lbs	23" W x 8.31" D x 7" H
HBC25-4	100,000 lbs	4	25,000 lbs	23" W x 8.5" D x 8.89" H
HBC50-4	200,000 lbs	4	50,000 lbs	14" W x 12" D x 9.3" H
HBC75-4	300,000 lbs	4	75,000 lbs	16" W x 12" D x 9.3" H
HBC100-4	400,000 lbs	4	100,000 lbs	consult factory

Accuracy classification: 0.2% full scale

TANK/HOPPER KITS - FOUR LEG ASSEMBLIES WITH BALL PIVOT STANDS

Model Number	System Gross Capacity	Number of Load Cells	Number of Ball Pivot Stands	Cell Capacity
BPSSHBC10-4	40,000 lbs	2	2	10,000 lbs
BPSSHBC25-4	100,000 lbs	2	2	25,000 lbs
BPSSHBC50-4	200,000 lbs	2	2	50,000 lbs
BPSSHBC75-4	300,000 lbs	2	2	75,000 lbs

Accuracy classification: 0.25% full scale

Please note: Gross capacity includes the empty weight of the vessel.

THE
GUARDIAN

TANK & HOPPER SCALE KITS

Stainless Steel Stands Also Available



GUARDIAN MODEL SST HYDRAULIC LOAD CELLS

Model Number	Capacity (lb)	Vmin (lb)	Construction	NTEP CC Number	Safe Overload	Base Diameter (inches)	Height (inches)	Operating Temperature
SST10	10,000	0.76	STAINLESS STEEL	None	150% Capacity	4.2	3.4	-10° F to 104° F -23° C to 40° C
SST25	25,000	1.9		5.9		5.1		
SST50	50,000	3.8		7.5		7.8		
SST75	75,000	5.7		9.0		7.8		
SST100	100,000	7.6		10.0		7.8		
SST200	200,000	15.2		13.8		7.3		

* - Class III, 10,000 divisions multiple cells

Cardinal Scale reserves the right to improve, enhance, or modify features and specifications without prior notice.

Sold By:

Gulf Atlantic

INDUSTRIAL EQUIPMENT INCORPORATED

Concrete, Aggregate, and Material Handling Equipment

Concrete Solutions with Rock Solid Results

800-792-7427

ISO
REGISTERED MODEL



MADE IN USA